

Unit 5

Area & Volume

Area

Composite Area

Surface Area

Volume

Name: _____

IXL Username: _____

IXL Password: _____

Forms Username: _____

Forms Password: _____

Quizizz Username: _____

Quizizz Password: _____

Ed Puzzle Username: _____

Ed Puzzle Password: _____

Unit 5: Area & Volume Standards, Checklist and Concept Map

Georgia Standards of Excellence (GSE):

GSE6.G.1: Find area of right triangles, other triangles, special quadrilaterals, and polygons by composing into rectangles or decomposing into triangles and other shapes; apply these techniques in the context of solving real-world and mathematical problems

- Find the area of a polygon (regular or irregular) by dividing it into squares, rectangles, and/or triangles and find the sum of the areas of those shapes



GSE6.G.2: Find the volume of a right rectangular prism with fractional edge lengths by packing it with unit cubes of the appropriate unit fraction edge lengths, and show that the volume is the same as would be found by multiplying the edge lengths of the prism. Apply the formulas $V = lwh$ and $V = Bh$ to find volumes of right rectangular prisms with fractional edge lengths in the context of solving real-world and mathematical problems.



GSE6.G.4: Represent three-dimensional figures using nets made up of rectangles and triangles, and use the nets to find the surface area of these figures. Apply these techniques in the context of solving real-world and mathematical problems.

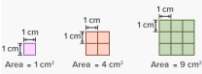
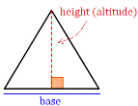

.....
What Will I Need to Learn??

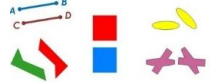
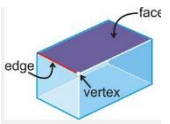
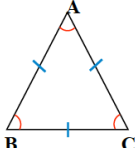
- _____ I can find the area of a polygon by splitting it up into squares, rectangles, and/or triangles, and finding the sum of all of the areas
- _____ I can find the volume of a right rectangular prism with fractional edges by packing it with unit cubes
- _____ I can apply the formula $V = lwh$ to find the volume of a right rectangular prism with fractional edge lengths
- _____ I can represent 3-dimensional shapes with nets
- _____ I can use nets to determine the surface area of 3-dimensional figures
- _____ I can apply these concepts of area, volume, and surface area to solve real-world and mathematical problems

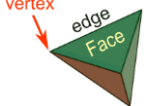
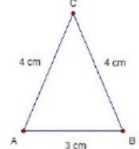
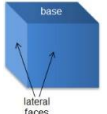
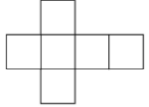
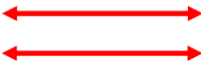
Unit 5 - Vocabulary

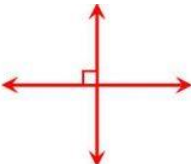
Term/Picture	Definition
Area 	The number of square units required to cover a surface
Base (of a triangle) 	The side of a triangle which is perpendicular to the height.
Base (of a polyhedron) 	The face or pair of faces from which the height of the polyhedron is measured.
Congruent 	Having the same size and shape
Cubic Units cm^3	The units used to measure volume
Edge 	The line segment where two faces of a solid figure meet
Equilateral Triangle 	A triangle with three congruent sides

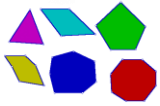
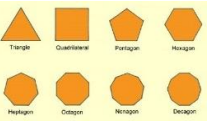
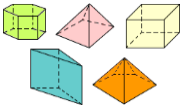
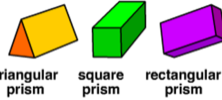
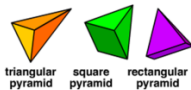
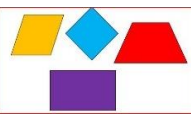
Term/Picture	Definition
Face 	A flat surface of a polyhedron
Isosceles Triangle 	A triangle with two equal sides
Lateral Faces 	Faces that are not bases in a 3D (polyhedron) figure
Net 	A flat shape that represents all of the faces of a 3D figure and can be folded to make that 3D figure
Parallel Lines 	Lines in the same plane that never intersect
Parallelogram 	A quadrilateral with two pairs of parallel sides
Perpendicular 	At an angle of 90° to a given line, plane, or surface

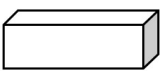
Term/Picture	Definition
Polygon 	A closed plane figure formed by three or more line segments
Regular Polygon 	A polygon with equal angles and equal sides
Polyhedron 	A solid figure with many sides, such as a pyramid
Prism 	A solid figure that has two congruent, parallel polygons as its bases and sides that are parallelograms
Pyramid 	A solid shape with a polygon as a base and triangular faces that come to a point (vertex or apex)
Quadrilateral 	A four-sided polygon
Rectangle 	A parallelogram with four right angles (opposite sides are parallel and congruent)
Rectangular Prism 	A prism that has rectangular bases

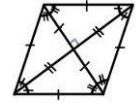
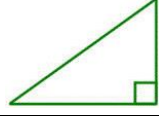
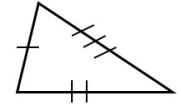
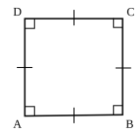
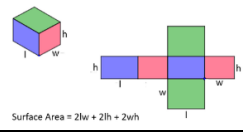
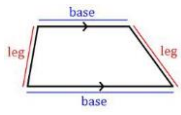
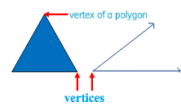
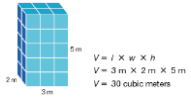
Term/Picture	Definition
Rhombus 	A parallelogram with opposite equal acute angles, opposite equal obtuse angles, and four equal sides
Right Triangle 	A triangle with one right angle
Scalene Triangle 	A triangle with no congruent sides
Square 	A parallelogram with four congruent sides and four right angles
Surface Area 	The sum of all the areas of all the faces or surfaces that enclose a solid
Trapezoid 	A quadrilateral with exactly one pair of parallel sides
Vertex (vertices) 	The point at which two lines segments, lines, or rays, meet to form an angle
Volume 	The amount of space INSIDE a 3D figure (polyhedron); How many unit cubes can fit INSIDE a 3D figure

Area of Parallelograms

Identifying and Classifying Polygons

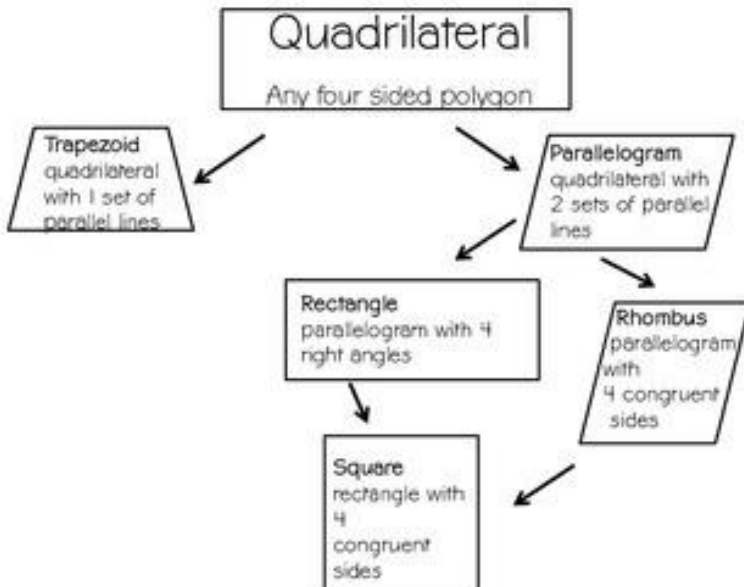
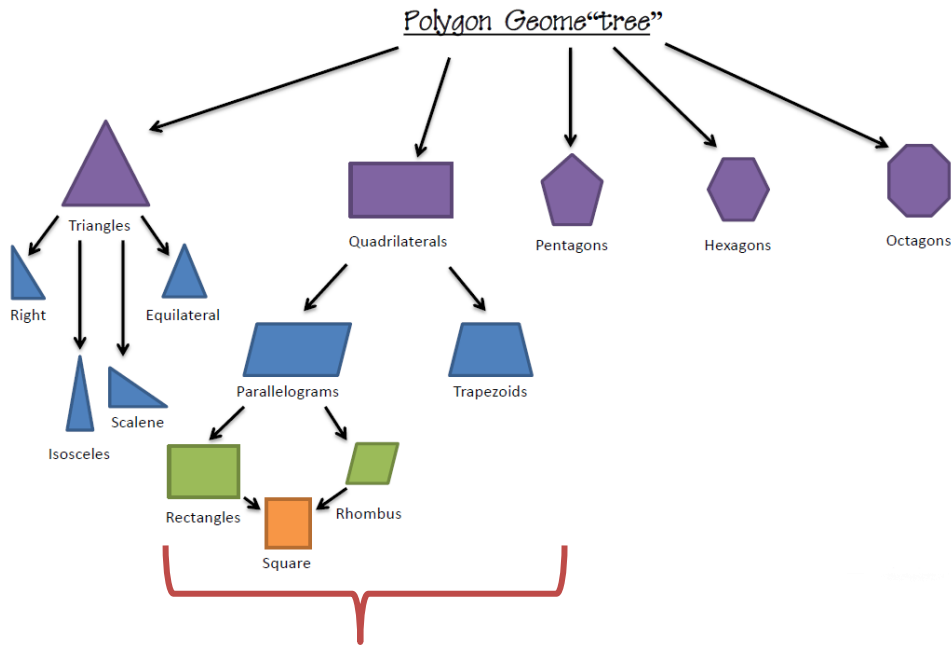

Identifying 3D Shapes

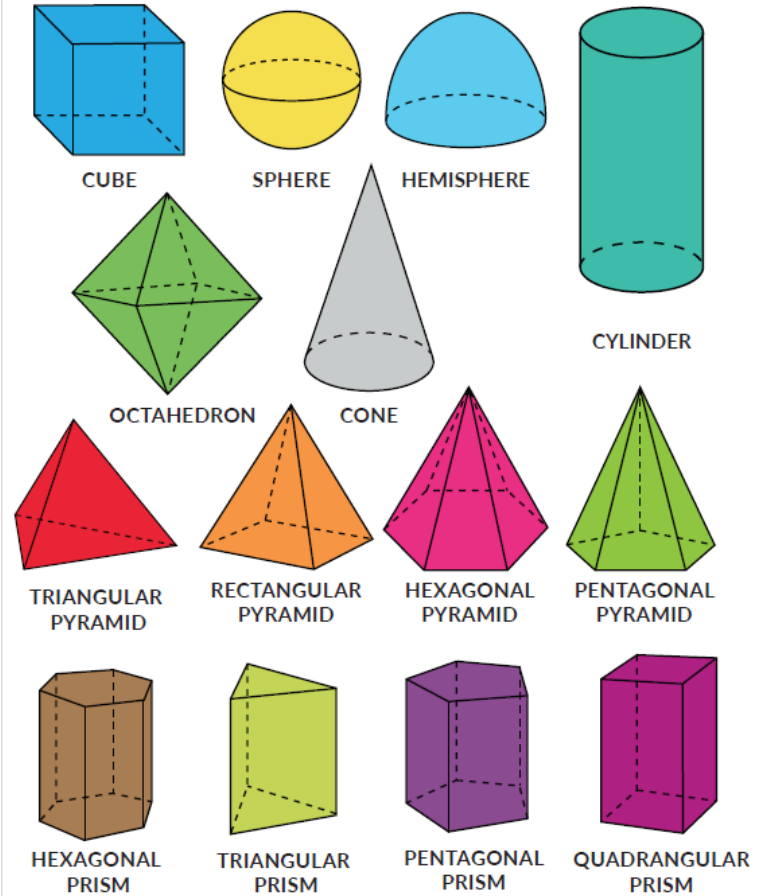

Nets of 3D Shapes

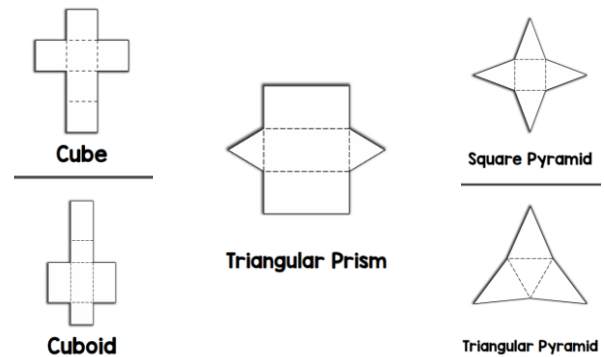

Area of Triangles and Quadrilaterals

Area is the amount of space INSIDE a figure. It is always measured in square units.

You can find area by counting the number of square units in a figure.

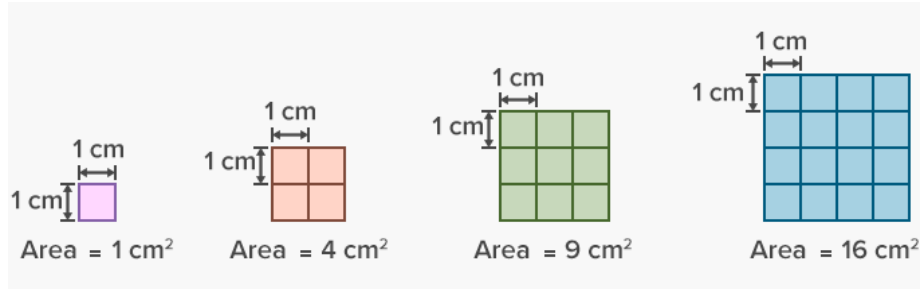

You can also find the area of a shape by using the area formula and substituting the values in for the variables.

Area

rectangle

$A = bh$

parallelogram

$A = bh$

triangle

$A = \frac{1}{2}bh$

trapezoid

$A = \frac{1}{2}(a+b)h$

<p>1) When calculating area, you can count the square units in a polygon.</p> <p>How many square units are there?</p>	<p>2) What is the area of this shape?</p>	<p>3) What is the area of this shape?</p>
<p>4) You can also use the formulas above to calculate the area of shapes.</p>	<p>5) What is the area of this shape?</p>	<p>6) What is the area of this shape?</p>

Area of a Parallelogram

Words The area A of a parallelogram is the product of its base b and its height h .

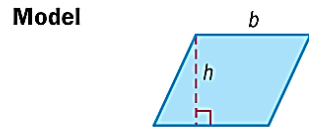

Symbols $A = bh$

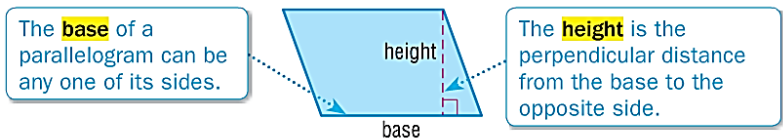

Parallelograms include special quadrilaterals, such as rectangles, squares, and rhombi.

Examples:

Find the area of the parallelogram.

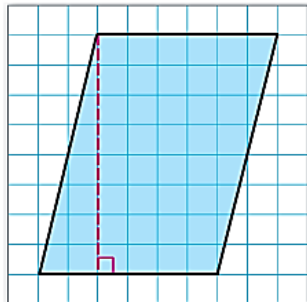

The base is 6 units, and the height is 8 units.

$A = bh$ Area of parallelogram
 $A = 6 \cdot 8$ Replace b with 6 and h with 8.
 $A = 48$ Multiply.

The area is 48 square units or 48 units².

Find the area of the parallelogram.

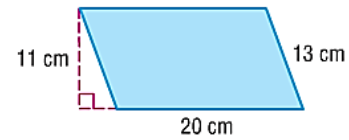

Estimate $A \approx 20 \cdot 10$ or 200 cm^2

$A = bh$ Area of parallelogram
 $A = 20 \cdot 11$ Replace b with 20 and h with 11.
 $A = 220$ Check for Reasonableness $220 \approx 200$ ✓

The area is 220 square centimeters or 220 cm².

You Try:

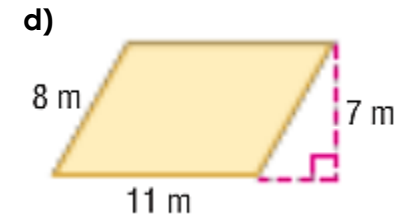
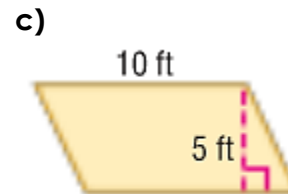
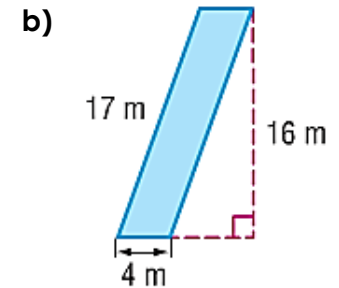
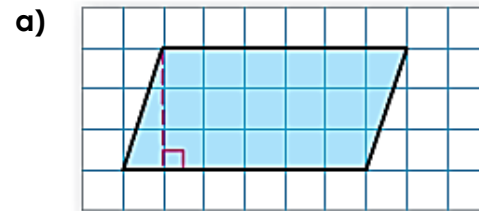

Area of Triangles

Area of a Triangle

Words The area A of a triangle is one half the product of the base b and its height h .

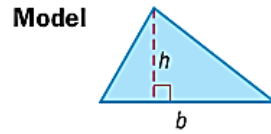

Symbols $A = \frac{1}{2}bh$ or $A = \frac{bh}{2}$

Congruent figures are figures that are the same shape and size.

A parallelogram can be formed by two congruent triangles. Since congruent triangles have the same area, the area of a triangle is one half the area of the parallelogram.

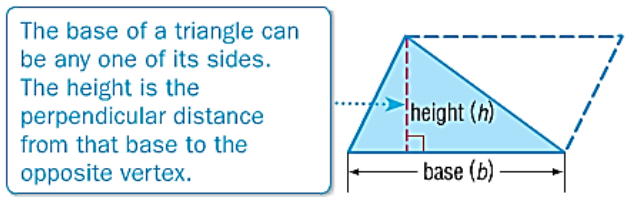

Examples:

Find the area of the triangle.

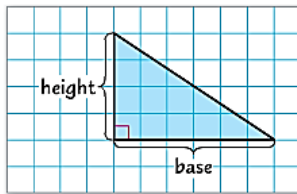

By counting, you find that the measure of the base is 6 units and the height is 4 units.

$$A = \frac{1}{2}bh \quad \text{Area of a triangle}$$

$$A = \frac{1}{2}(6)(4) \quad \text{Replace } b \text{ with 6 and } h \text{ with 4.}$$

$$A = \frac{1}{2}(24) \quad \text{Multiply.}$$

$$A = 12 \quad \text{Multiply.}$$

The area of the triangle is 12 square units.

Find the area of the triangle.

$$A = \frac{1}{2}bh$$

Area of a triangle

$$A = \frac{1}{2}(12.1)(6.4)$$

Replace b with 12.1 and h with 6.4.

$$A = \frac{1}{2}(77.44)$$

Multiply.

$$A = 38.72$$

Divide. $\frac{1}{2}(77.44) = 77.44 \div 2$, or 38.72

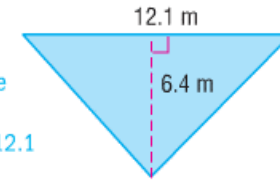

The area of the triangle is 38.72 square meters.

You Try:

a)

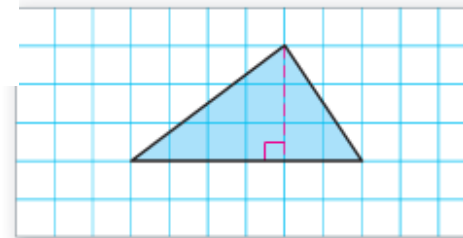

b)

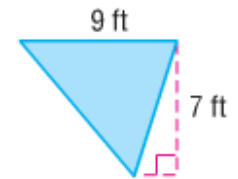

c)

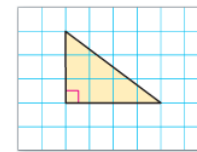

d)

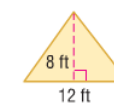

e)

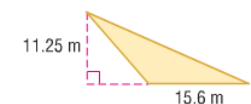

Area of Trapezoids

Area of a Trapezoid

Words The area A of a trapezoid is one half the product of the height h and the sum of the bases b_1 and b_2 .

Model

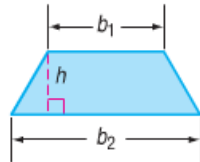

Symbols $A = \frac{1}{2}h(b_1 + b_2)$

A trapezoid has two bases, b_1 and b_2 . The height of a trapezoid is the distance between the bases.

The height is the perpendicular distance between the bases.

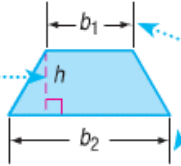

The two bases are parallel. They will always be the same distance apart.

When finding the area of a trapezoid, it is important to follow the order of operations. In the formula, the bases are to be added before multiplying by $\frac{1}{2}$ of the height h .

You Try:

Find the area of the trapezoid.

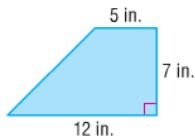

The bases are 5 inches and 12 inches. The height is 7 inches.

$$A = \frac{1}{2}h(b_1 + b_2) \quad \text{Area of a trapezoid}$$

$$A = \frac{1}{2}(7)(5 + 12) \quad \text{Replace } h \text{ with 7, } b_1 \text{ with 5, and } b_2 \text{ with 12.}$$

$$A = \frac{1}{2}(7)(17) \quad \text{Add 5 and 12.}$$

$$A = 59.5 \quad \text{Multiply.}$$

The area of the trapezoid is 59.5 square inches.

Find the area of the trapezoid.

$$A = \frac{1}{2}h(b_1 + b_2) \quad \text{Area of a trapezoid}$$

$$A = \frac{1}{2}(9.8)(7 + 12) \quad \text{Replace } h \text{ with 9.8, } b_1 \text{ with 7, and } b_2 \text{ with 12.}$$

$$A = \frac{1}{2}(9.8)(19) \quad \text{Add 7 and 12.}$$

$$A = 93.1 \quad \text{Multiply.}$$

So, the area of the trapezoid is 93.1 square meters.

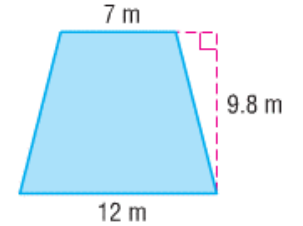

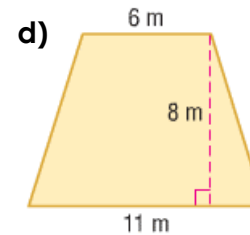
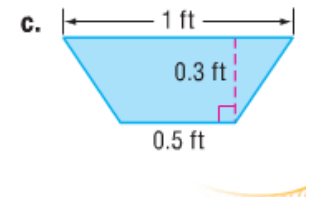
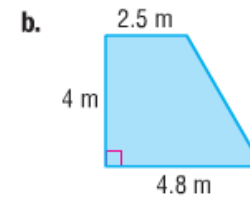
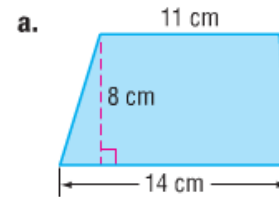

You Try:

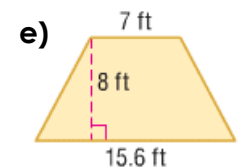

Show your work.

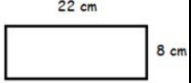
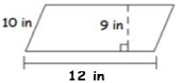
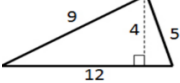

Practice with Area

Name of Polygon	Picture	Write the formula	Substitute for the variables (Show work)	Solve. Include square units in your answer.
				
				
				
				

Skills Practice

Find the area of each polygon. Show all steps!

Step 1: Write your formula.
Step 2: Substitute for the base(s) and height.
Step 3: Solve. Include units in your answer!

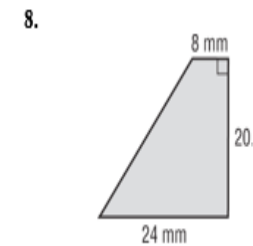
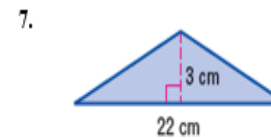
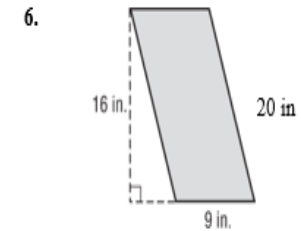
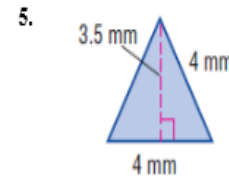
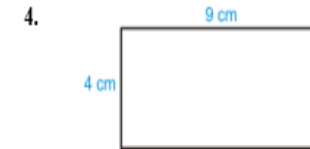
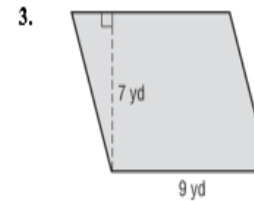
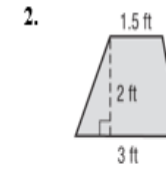
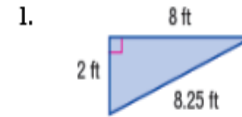

Area Error Analysis



Fill in the Flow Map with the 3 steps to solving problems on area:



Silly Sally has struck again! Analyze her work in Column #1, and circle her mistake. In Column #2, explain what she did wrong. In Column #3, work out the problems correctly, showing ALL work!

Silly Sally's Work (Circle her mistake):	What did Silly Sally do wrong?	Show Silly Sally how it's done! (Show ALL steps!)
$A = lw$ $12 \cdot 8$ 20 m^2		
$A = \frac{1}{2}bh$ $\frac{1}{2} \cdot 4 \cdot 6$ 24 cm^2		
$A = \frac{1}{2}bh$ $\frac{1}{2} \cdot 8 \cdot 9$ $\frac{1}{2} \cdot 72$ 36 m^2		

Area of Composite Figures

A **composite figure** is a figure made of two or more two-dimensional figures. The composite figure shown to the right is made of two rectangles.

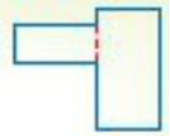

Find the Area of a Composite Figure

You can decompose some trapezoids into a square and a triangle to find the area.

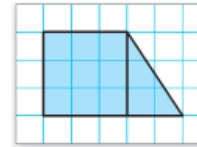

Area of Square

$$A = \ell \cdot w$$

$$A = 3 \cdot 3, \text{ or } 9$$

Area of Triangle

$$A = \frac{1}{2}bh$$

$$A = \frac{1}{2}(2)(3), \text{ or } 3$$

Then add the area of the square and the area of the triangle to find the area of the trapezoid. The area of the trapezoid is $9 + 3$ or 12 square units.

You can find the area of a composite figure using the same strategy. To find the area of a composite figure, separate it into figures with areas you know how to find. Then add those areas.

Example



1. Find the area of the figure at the right.

The figure can be separated into a rectangle and a triangle. Find the area of each.

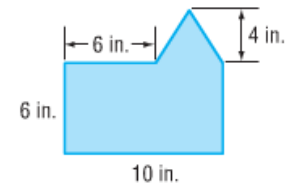

Area of Rectangle

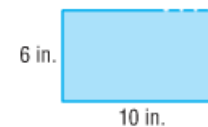

$$A = \ell w$$

$$A = 10 \cdot 6 \text{ or } 60$$

Area of Triangle

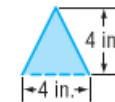

$$A = \frac{1}{2}bh$$

$$A = \frac{1}{2}(4)(4) \text{ or } 8$$

The base of the triangle is $10 - 6$ or 4 inches.

The area is $60 + 8$ or 68 square inches.

The figure below is a composite figure. How would you find its area?

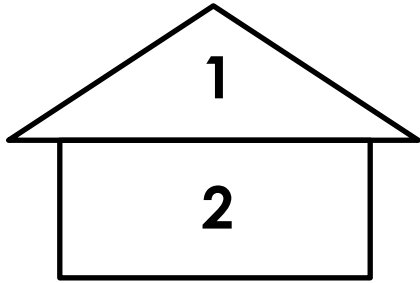

The house is made up of two shapes that you are familiar with – a triangle and a rectangle. You can “decompose” or “take apart” the figure to find the area of each piece and then find the sum of those areas to get the total area.

Try This:

Find the area of the rocket figure below.

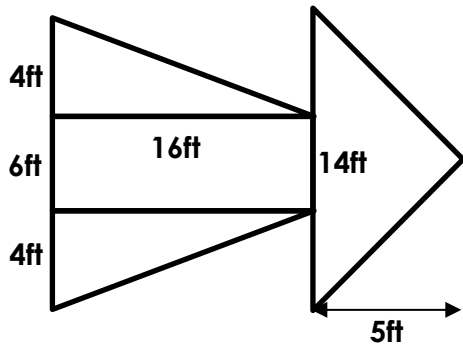

- 1) How many shapes can this figure be broken into?
- 2) What two different types of shapes can you see?
- 3) Determine the area of each shape.

Shape	Shape #1	Shape #2	Shape #3	Shape #4
Formula	$\text{Area}_{\Delta} = \frac{1}{2}bh$			
Work	$\frac{1}{2} \cdot 16 \cdot 4$ $8 \cdot 4$			
Solution	32 ft ²			

Lastly, add the area of each piece. Total Area = _____

You Try:

Find the area of each composite figure. Remember to show all work! (Hint: Often, you will have to draw in lines to decompose the figure. Pay careful attention to the side lengths that are given so you can figure out the side lengths that are missing!)

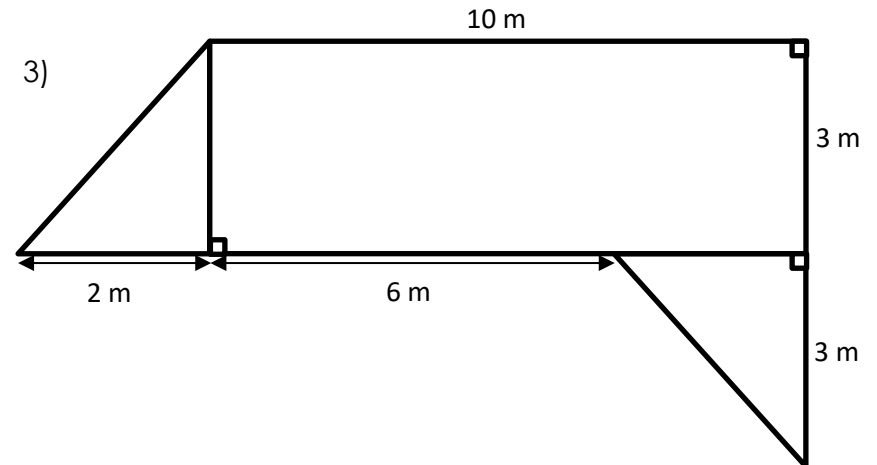
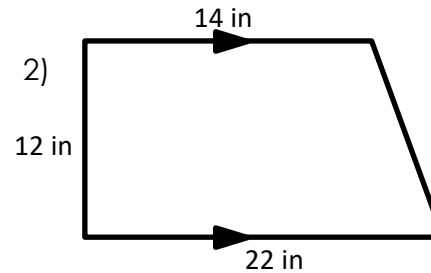
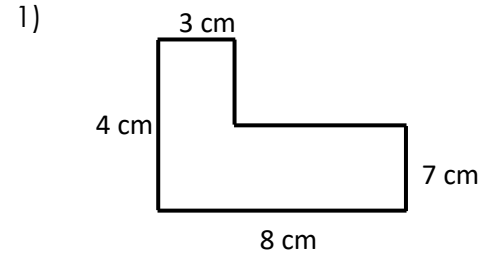

Find the area of each composite figure:

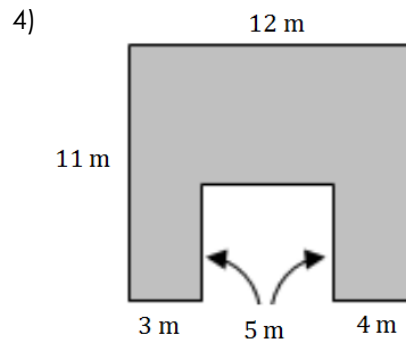
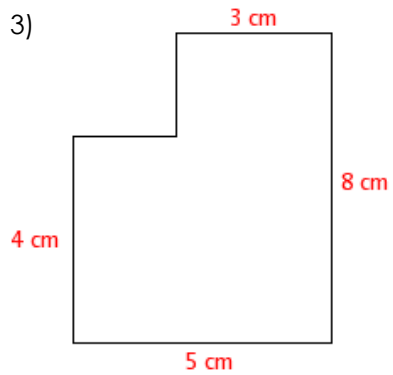
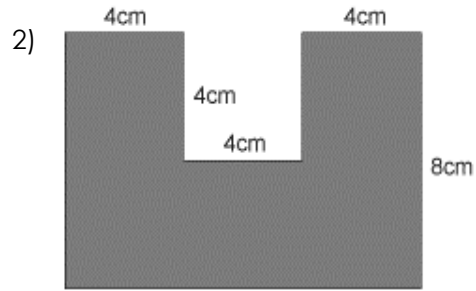
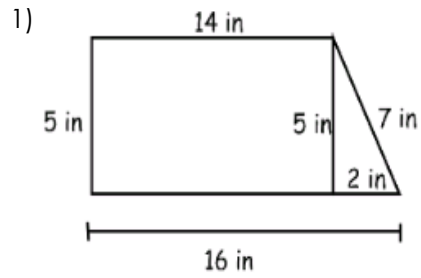

More Area Practice with Composite Figures

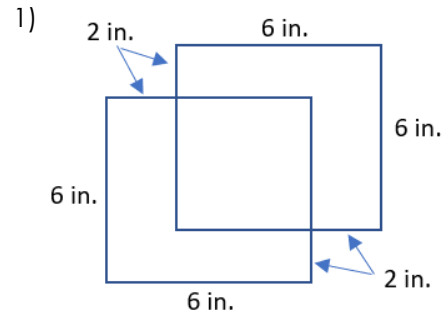

2) Find the area of the shaded region.

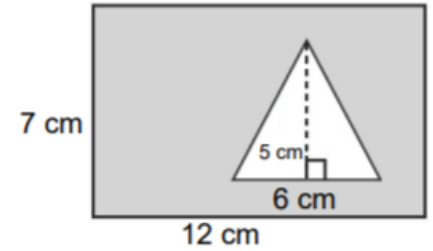

3) Match each math sentence with the correct division of the complex figure below.

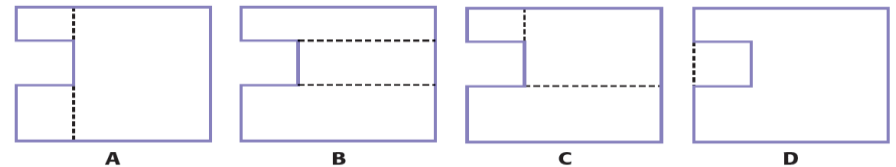
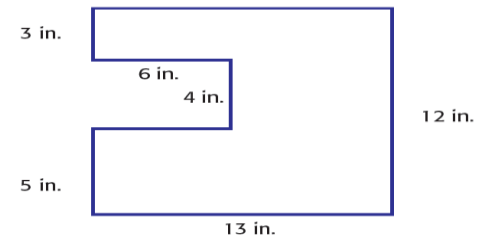

4. $(6 \times 3) + (7 \times 7) + (13 \times 5)$

5. $(6 \times 3) + (6 \times 5) + (7 \times 12)$

6. $(13 \times 12) - (6 \times 4)$

7. $(13 \times 3) + (7 \times 4) + (13 \times 5)$

Attributes of Common Polyhedrons

A **polyhedron** is a 3D figure in which all faces are polygons.

(The plural form is polyhedra or polyhedrons.)

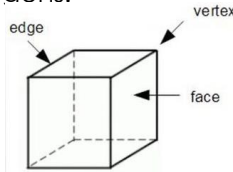

Prism vs. pyramid:

Prisms have **2 bases** and all of their **lateral faces are rectangular**.

Pyramids have **1 base** and all of their **lateral faces are triangular** and meet at a vertex.

	Polyhedron	Attributes	Nets
Prisms	Cube 	6 faces 12 edges 8 vertices	
	Rectangular Prism 	6 faces 12 edges 8 vertices	
	Triangular Prism 	5 faces 9 edges 6 vertices	
Pyramids	Square Pyramid 	5 faces 8 edges 5 vertices	
	Triangular Pyramid 	4 faces 6 edges 4 vertices	

Challenge:

Can You Find ALL The Nets That Make a Cube?

Before you begin, think of the basics:

- 1) A net is an "unfolded" 3D shape. You're looking for all nets that could fold up to make a cube.
- 2) The net must consist of exactly 6 squares.
- 3) None of the squares can overlap.

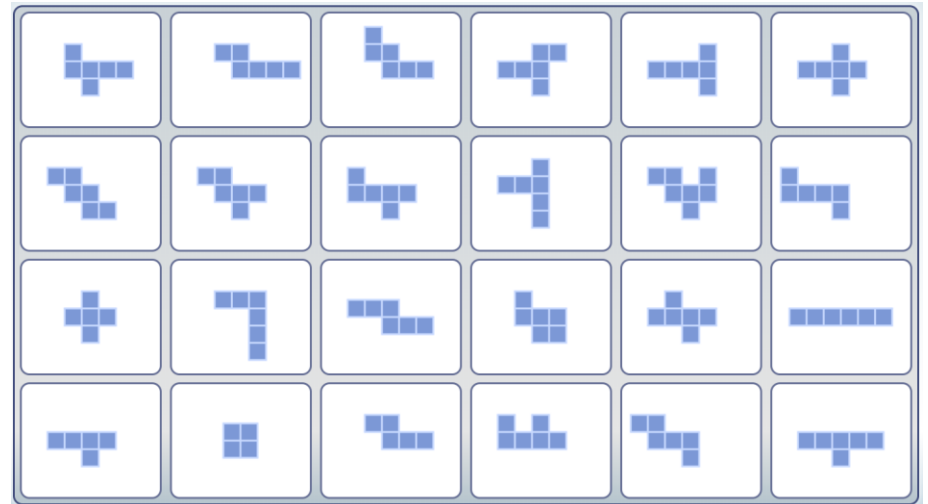

Check your answers at this site, also posted in CTLs:

<https://www.nctm.org/Classroom-Resources/Illuminations/Interactives/Cube-Nets/>

How did you do?







Were you surprised by any of the answers? Explain.

Nets of 3-Dimensional Figures

Face is a flat side of a solid figure.

Edge is a line segment where two faces of a polyhedron meet.

Vertex is a point where 2 or more edges of a solid figure meet or the pointed end of a cone opposite its base.

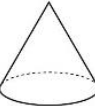
FIGURE	FACES Look Like	BASE	How many faces?	NET
Cube 				
Rectangular Prism 				
Triangular Prism 				
Square Pyramid 				
Triangular Pyramid 				
Cylinder 				
Cone 				

Matching Nets and 3-D Figures

Using Nets to Understand 3-D Figures - Matching Worksheet

Write the letter of the shape that each net would create.

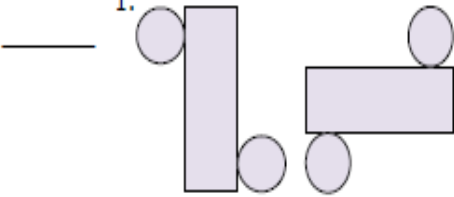
1. 

2. 

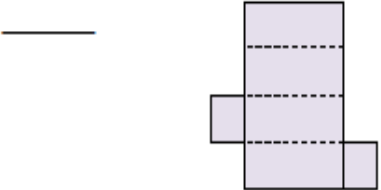
3. 

4. 

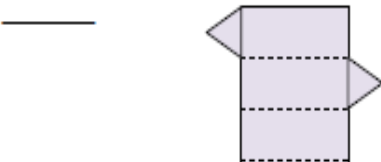
5. 

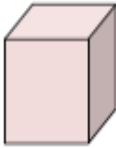
a. 

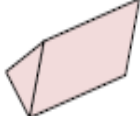
b. 

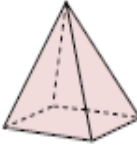
c. 

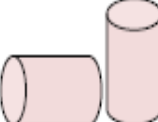
d. 

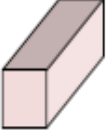
e. 

Surface Area

Surface area is the total area of all surfaces of a 3D figure, measured in square units.

Key Understandings:

- 1) **Surface area** measures the AREA of the **outside** of a three dimensional figure (polyhedron).
- 2) **Examples** that relate to surface area include:
 - how much cardboard needed to make a cereal box
 - how much paint needed to paint a doghouse
 - how many tiles it will take to cover a floor
- 3) Even though surface area is the area of the outside of polyhedra, it is always measured in square units just like all area calculations. This is because surface area only measures the area of the flat surfaces that make up the shape (the nets).

Example 1: Find the surface area of the **rectangular prism**.

First, find the area of each face:

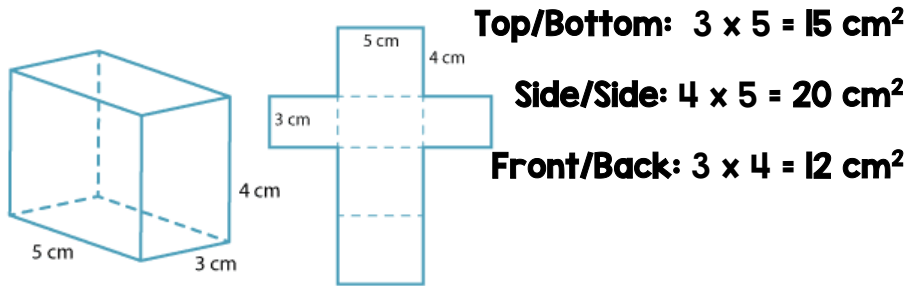

Then, find the **total** area:

$$2(15 + 20 + 12) = 2(47) = \mathbf{94 \text{ cm}^2}$$

Example 2: Find the surface area of the **cube**.

First, find the area of each face. Keep in mind all faces of a cube are congruent.:

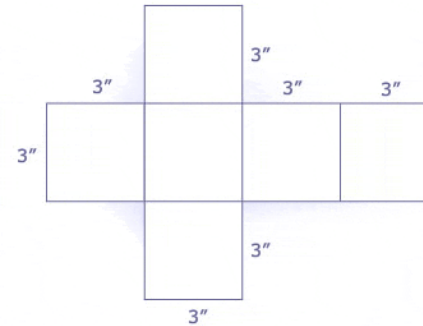

$$3 \times 3 = 9 \text{ in}^2$$

Then, find the **total** area:

$$6 \times 9 = \mathbf{54 \text{ in}^2}$$

The formula for surface area of a cube is $SA = 6s^2$

Example 3: Find the surface area of the **rectangular pyramid**.

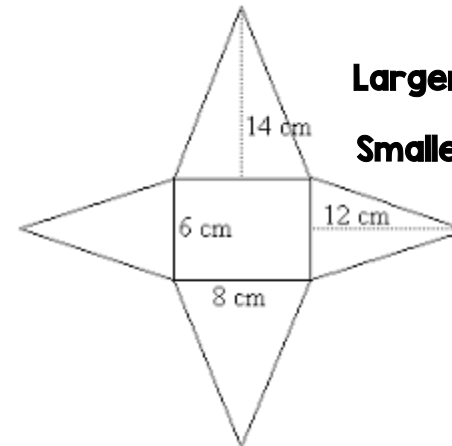

$$\text{Larger Triangle: } \frac{1}{2} \times 8 \times 14 = 56 \text{ cm}^2$$

$$\text{Smaller Triangle: } \frac{1}{2} \times 6 \times 12 = 36 \text{ cm}^2$$

$$\text{Rectangle: } 6 \times 8 = 48 \text{ cm}^2$$

Then, find the **total** area:

$$2(56) + 2(36) + 48 =$$

$$112 + 72 + 48 = \mathbf{232 \text{ cm}^2}$$

You Try:

Using either method (nets or formulas), find the surface area.

1)

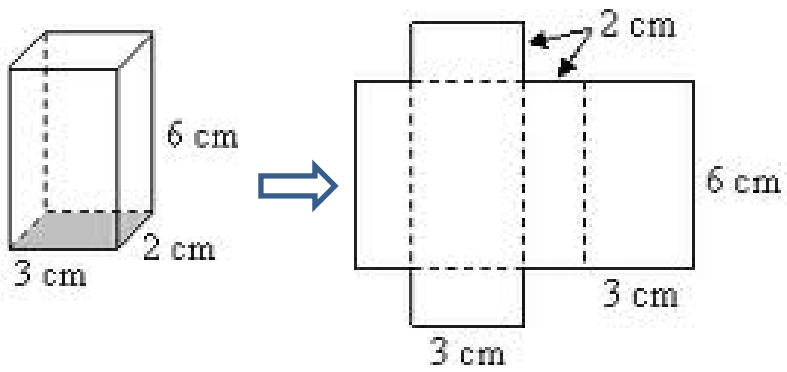

4)

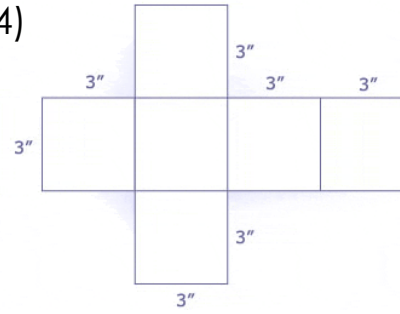

5)

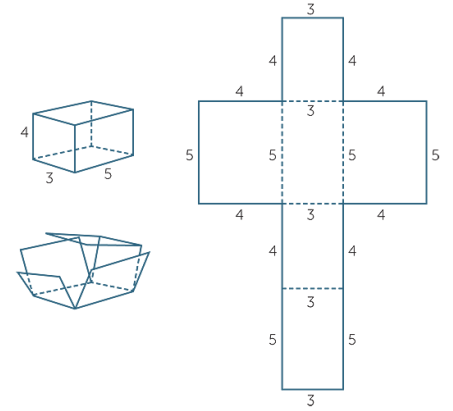

2)

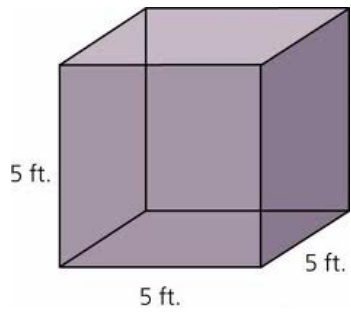

3)

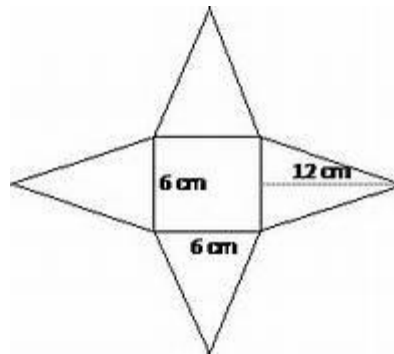

6)

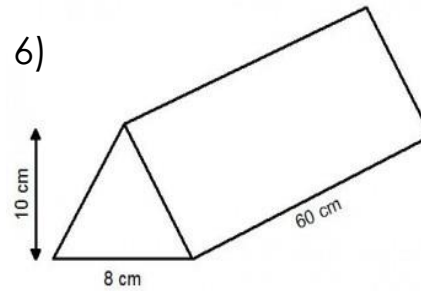

7) Find the Surface Area of a cube with side length 4cm.

8)

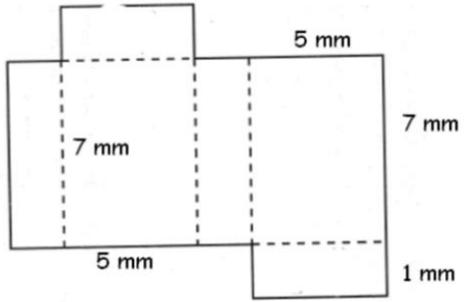

10)

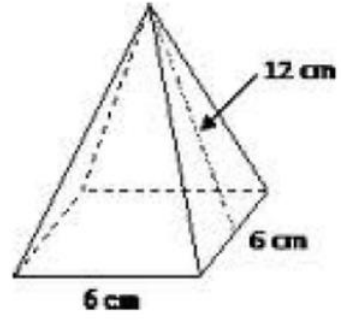

9)

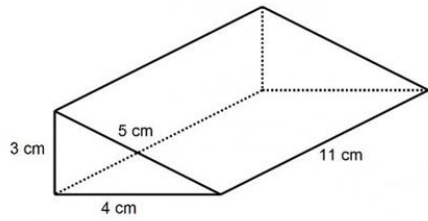

11)

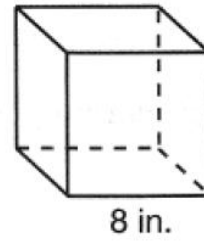

Surface Area in the Real World

Solve each of the problems by drawing a net and finding the surface area.

- 1) A pizza box is 15 inches wide, 14 inches long, and 2 inches tall. How many square inches of cardboard were used to create the box?



- 2) What is the surface area of a Rubik's Cube that is 6 cm tall?



- 3) Angelo is making a replica of an Egyptian pyramid. He is making a square pyramid with a base that is 3 feet long and 3 feet wide. The triangular sides of the pyramid each have a height of 14 feet. How much material will Angelo need to cover the pyramid?



- 4) Sydney is painting a rectangular toy box for her little brother. She will paint all 4 sides and the top (she will NOT paint the bottom). If the toy box is 20 inches tall, 12 inches wide, and 25 inches long, how many square inches will she need to paint?



- 5) DeAndre is making a tent for his hamster. It is 20 cm long, and the triangular bases are 15 cm high and 10 cm wide (see picture below). How much material will he need to make the tent?

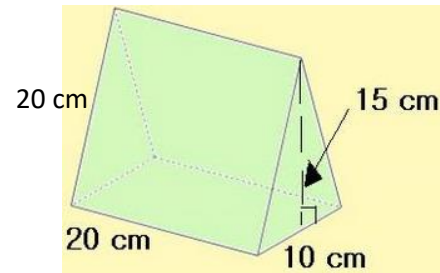

Volume of Rectangular Prisms

Volume is the amount of space *inside* a 3D object, measured in *cubic units*.

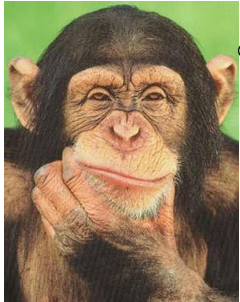

Ever wonder WHY volume is measured in *cubic units*??

Since volume measures the amount of space **INSIDE** a figure, it's like you're *packing the figure with little tiny cubes*!!

Here's a visual of a **rectangular prism** being packed with unit cubes...

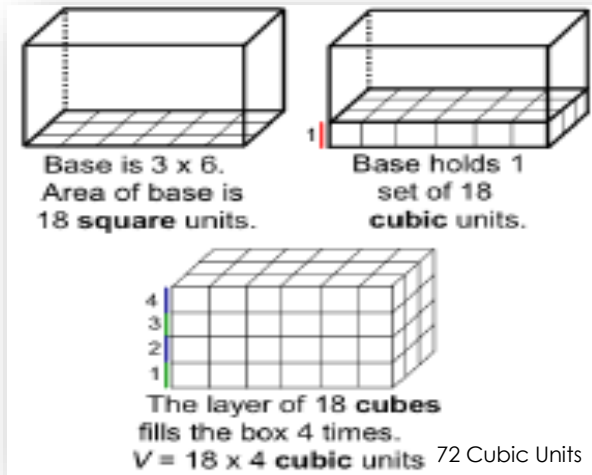

Here's a visual of a **cube** being packed with unit cubes...

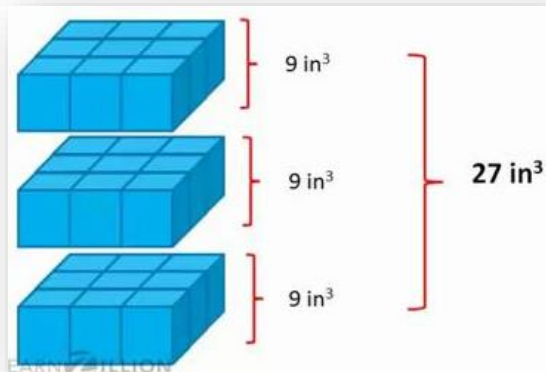

Volume is the number of cubic units needed to fill the space in a three dimensional (3D) figure. **Volume is always measured in cubic units.**

We calculate volume you must find the area of the base then multiply it by the height.

This can be written as $B \cdot h$.

OR $l \cdot w \cdot h$ for a rectangular prism.

Example:

Find the volume of the rectangular prism below.

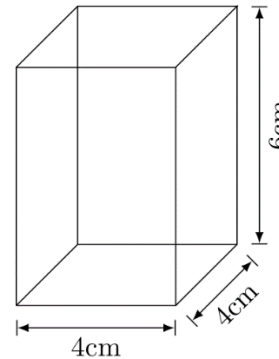

$$V = B \cdot h$$

$$V = l \cdot w \cdot h$$

$$V = 4 \cdot 4 \cdot 6$$

$$V = 96 \text{ cm}^3$$

You Try:

Find the volume.

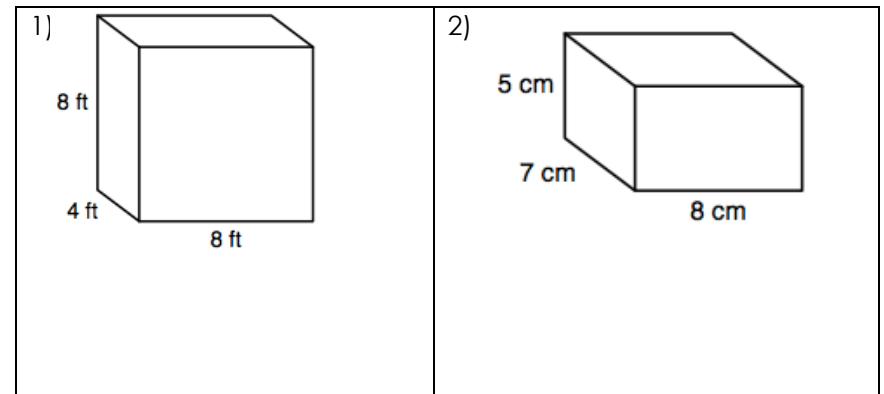

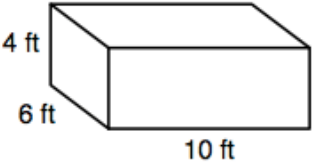
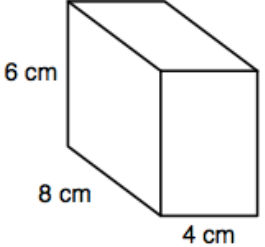
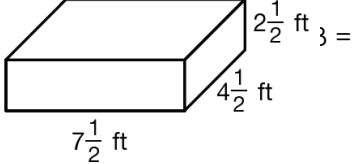
<p>3) </p>	<p>4) </p>
<p>5)  =</p>	<p>6) Find the volume of a rectangular prism with $l = 4.2\text{cm}$, $w = 3.8\text{cm}$, and $h = 6\text{cm}$.</p>
<p>7) Find the volume of a rectangular prism with $l = 8\frac{1}{4}\text{in.}$, $w = 9\text{in}$ and $h = 15\text{in.}$</p>	<p>8) Find the missing dimension of the rectangular prism. $L = 14\text{ cm}$ $W = ?$ $H = 3\text{ cm}$ $V = 294\text{ cm}$</p>

More Volume Practice

Solve each problem. Include units and show your work!

1. Find the volume of the cube.

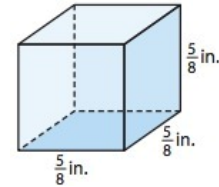

2. Find the volume of the prism below.

3. The dimensions of the prism below are given in inches. How many $\frac{1}{2}$ -inch cubes will fit inside this prism?

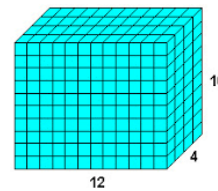

4. How many 3-inch Rubik's Cubes can fit inside a cubic shipping box that is 4 feet wide?

Volume Error Analysis

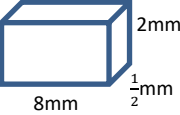
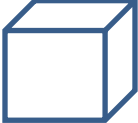
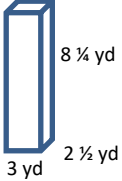
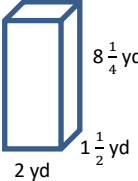

Sally is a silly little girl that makes silly mistakes! Analyze her work in Column #1, and circle her mistake. In Column #2, explain what she did wrong. In Column #3, show how Silly Sally should work out the problem. Show ALL work!

Silly Sally's Work (Circle her mistake):	What did Silly Sally do wrong?	Show Silly Sally how it's done! (Show ALL steps!)
 $V = l w h$ $V = 4 \cdot 4 \cdot 4$ $V = 12 \text{ m}^3$		
 $V = l w h$ $V = 8 \cdot \frac{1}{2} \cdot 2$ $V = 4 \cdot 2$ $V = 8 \text{ mm}^2$		
 $V = l w h$ $V = \frac{2}{3} \cdot \frac{2}{3} \cdot \frac{2}{3}$ $V = \frac{6}{9} = \frac{2}{3} \text{ in}^3$ <p>Cube = 2/3 in. tall</p>		
 $V = l w h$ $V = 8 \frac{1}{4} \cdot 2 \frac{1}{2} \cdot 3$ $V = 16 \frac{1}{8} \cdot 3$ $V = 48 \frac{1}{8} \text{ yd}^3$		
 $V = l w h$ $V = 4 \frac{1}{2} \cdot 1 \frac{1}{2} \cdot 2$ $V = \frac{8}{2} \cdot \frac{3}{2} \cdot 2$ $V = \frac{24}{4} \cdot 2$ $V = 12 \text{ yd}^3$		

More Volume Practice

Determine the Volume of each rectangular prism or cube below. Include units and show your work!

- A cube that is 12 yards wide
- The box with dimensions of 6 ft • 4 ft • 1 ½ ft
- Determine the Volume of a rectangular truck bed that is 12 feet long, 5 ¼ feet wide, and 3 feet deep.
- How much water can be poured into a cubic tank that is 2 ½ feet long?
- What is the volume of a gift box that is 3 ½ inches wide, 2 inches tall, and 6 inches long?

SURFACE AREA AND VOLUME PRACTICE

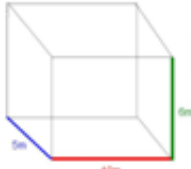
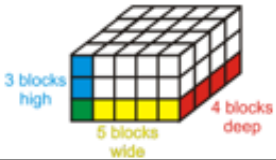
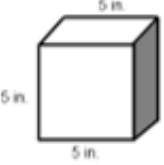
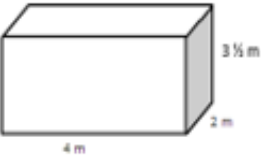
Rectangular Prism:	Surface Area (Show work and circle your answer.) (It may help to draw a net!)	Volume (Show work and circle your answer.) $V = lwh$ OR $V = Bh$
	1) SA =	2) V =
	3) SA =	4) V =
	5) SA =	6) V =
	7) SA =	8) V =

9) Circle the choices that relate to **volume**. Underline the choices that relate to **surface area**.

Filling a pool with water Wrapping a present The amount of cereal in a box Painting a doghouse

10) How are surface area and volume alike? _____

11) Name 2 ways surface area and volume are different.

a. _____

b. _____

More Surface Area & Volume Practice

Find the volume and surface area of each prism.

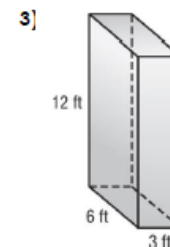
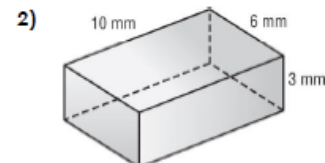
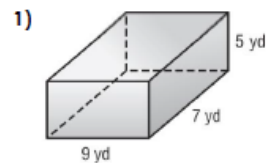

Find the volume of each prism.

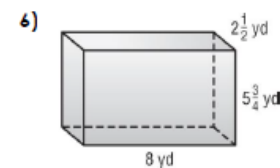
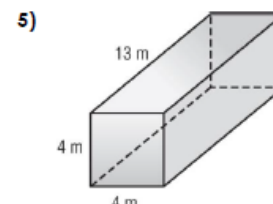
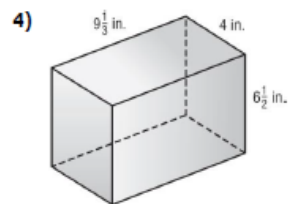

7) **TOYS** Geneva's younger brother has a toy box that is 3.6 feet long, 2.4 feet wide, and 1.5 feet high. What is the volume of the toy box?

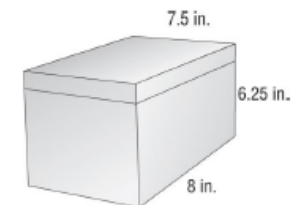

8) What is the volume of a rectangular prism with a length of 11 meters, width of 26 meters, and height of 38 meters?

9) **BAKING** The bread loaf pan shown is filled to a height of 2 inches with banana bread batter. How much more batter could the pan hold before it overflowed?



Math 6 – Unit 5: Area & Volume Review

Knowledge & Understanding

- 1) How could you determine the area of a composite figure, such as the ones shown here?

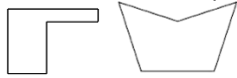

- 2) What types of units are used to describe area? _____
- 3) What types of units are used to describe volume? _____

Proficiency of Skills

- 4) Determine the volume of the cube: _____

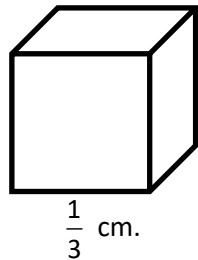

- 5) Find the area of the shaded section of the square: _____

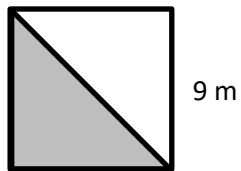

- 6) Find the area of the triangle: _____

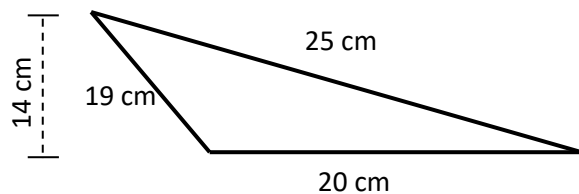

- 7) Determine the area of the trapezoid: _____

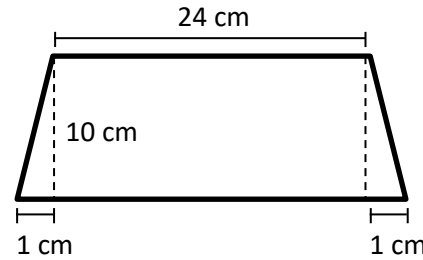

- 8) The surface area of a cube can be found by using the formula $SA = 6s^2$. Determine the surface area of a cube with a length of 8cm.

- 9) Find the area of the figure shown below: _____

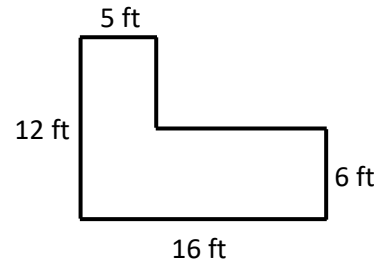

Application

- 10) If carpet costs \$4 per square yard, how much would it cost to carpet a rectangular room that is 6 yards wide and 10 yards long? _____

- 11) What is the area of the trapezoid? _____

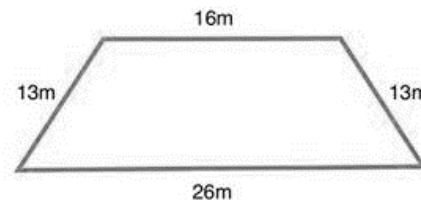

- 12) A rectangular prism is filled with small cubes of the same size. The bottom layer consists of 9 cubes, each with a volume of 2 cubic inches. If there are 3 layers of cubes in the prism, what is the volume of the rectangular prism? _____

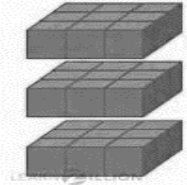

- 13) A box is made of cardboard with no overlap. The net of the box is shown below. How many square inches of cardboard is needed to make the box? _____

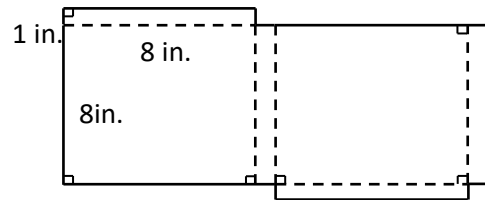

- 14) The triangular sides of the tent are equilateral, with a base of 20 inches and a height of 15 inches. The three rectangular sides of the tent are each 50 inches long and 20 inches wide. What is the surface area of the tent? _____



- 15) Mariah and Max are making a plaque to dedicate to the swaggerific saxophone players of the ECMS sixth-grade band. The center is a 10-inch square, and the edges of the frame measure 12 inches long and 12 inches wide. What is the area of the frame? _____

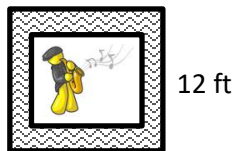

- 16) A fish tank is shown below. What is the volume of the water in the tank? _____

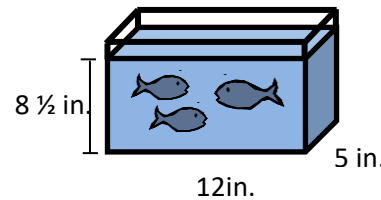

- 17) How many cubic feet are in a cubic yard? _____

- 18) The volume of a rectangular prism can be found by using the formula $V=Bh$. If the base of a prism is square with a side length of 3 inches and the height of the prism is $2\frac{1}{4}$ inches, find the volume of the prism. _____

- 19) Andres is painting five faces of a storage cube (he isn't painting the bottom face). If each faces is 8 inches, how many square inches will he need to paint? _____

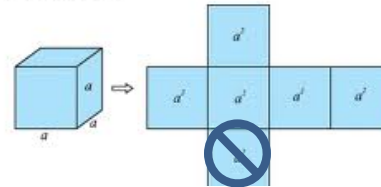

- 20) Which of the following nets could NOT be folded to form a cube?

