

Unit 5

Area & Volume

Area
 Composite Area
 Surface Area
 Volume

Name: _____

Math Teacher: _____

Unit 5 IXL Log

<u>Required Skills</u>			
	<u>Skill</u>	<u>Your Score</u>	
Week of 11/18	CC.1	Identify and classify polygons	
	CC.6	Identify trapezoids	
	CC.7	Classify quadrilaterals	
	FF.2	Area of rectangles and squares	
	FF.3	Area of triangles	
	FF.4	Area of parallelograms and trapezoids	
Week of 12/2	FF.5	Area of quadrilaterals	
	EE.1	Identify polyhedral	
	EE.2	Which figure is being described?	
	EE.3	Nets of 3D figures	
	FF.6	Area of compound figures	
	FF.7	Area between two rectangles	
Week of 12/9	FF.8	Area between two triangles	
	FF.16	Surface area of cubes and rectangular prisms	
	FF.9	Rectangles: relationship between perimeter and area	
	FF.14	Volume of cubes and rectangular prisms	
	FF.15	Volume of cubes and rectangular prisms: word problems	

Unit 5: Area & Volume Standards, Checklist and Concept Map

Georgia Standards of Excellence (GSE):

MGSE6.G.1: Find area of right triangles, other triangles, special quadrilaterals, and polygons by composing into rectangles or decomposing into triangles and other shapes; apply these techniques in the context of solving real-world and mathematical problems

- Find the area of a polygon (regular or irregular) by dividing it into squares, rectangles, and/or triangles and find the sum of the areas of those shapes

MGSE6.G.2: Find the volume of a right rectangular prism with fractional edge lengths by packing it with unit cubes of the appropriate unit fraction edge lengths, and show that the volume is the same as would be found by multiplying the edge lengths of the prism. Apply the formulas $V = lwh$ and $V = Bh$ to find volumes of right rectangular prisms with fractional edge lengths in the context of solving real-world and mathematical problems.

MGSE6.G.4 : Represent three-dimensional figures using nets made up of rectangles and triangles, and use the nets to find the surface area of these figures. Apply these techniques in the context of solving real-world and mathematical problems.

.....
What Will I Need to Learn??

- _____ I can find the area of a polygon by splitting it up into squares, rectangles, and/or triangles, and finding the sum of all of the areas
- _____ I can find the volume of a right rectangular prism with fractional edges by packing it with unit cubes
- _____ I can apply the formula $V = lwh$ to find the volume of a right rectangular prism with fractional edges
- _____ I can represent 3-dimensional shapes with nets
- _____ I can use nets to determine the surface area of 3-dimensional figures
- _____ I can apply these concepts of area, volume, and surface area to solve real-world problems

Math 6/7 Unit 5 Calendar

11/18	11/19	11/20	11/21	11/22
Unit 5 Pre-Test MSG Set Up Unit Overview	Area of Parallelograms, Rectangles, Squares and Triangles Formula Organizer	Computer Lab (Desmos and IXL)	Area of Composite Figures	Area Quiz
11/25	11/26	11/27	11/28	11/29
THANKSGIVING BREAK!				
12/2	12/3	12/4	12/5	12/6
Composite Area, Nets, and Surface Area	Computer Lab (Desmos and IXL)	Surface Area	Surface Area	Surface Area Quiz
12/9	12/10	12/11	12/12	12/13
Volume	Math Inventory	Volume	Surface Area vs. Volume	Volume & Quick Quiz
12/16	12/17	12/18	12/19	12/20
Review	Mini Post-Test, Review	Unit 5 Test in Computer Lab	Early Release (Review activity)	Early Release (Review activity)

Unit 5 - Vocabulary

Term	Definition and/or Picture/Example
Area	
Base (of a triangle)	
Base (of a 3D figure)	
Congruent	
Cubic Units	
Edge	
Equilateral Triangle	

Term	Definition and/or Picture/Example
Face	
Isosceles Triangle	
Lateral Faces	
Net	
Parallel	
Parallelogram	
Perpendicular	

Term	Definition and/or Picture/Example
Polygon	
Regular Polygon	
Polyhedron	
Prism	
Pyramid	
Quadrilateral	
Rectangle	
Rectangular Prism	

Term	Definition and/or Picture/Example
Rhombus	
Right Triangle	
Scalene Triangle	
Square	
Surface Area	
Trapezoid	
Vertex (vertices)	
Volume	

Math 6 – Unit 5: Area & Volume Review

Knowledge & Understanding

- 1) How could you determine the area of a composite figure, such as the ones shown here?



- 2) What types of units are used to describe area? _____
- 3) What types of units are used to describe volume? _____

Proficiency of Skills

- 4) Determine the volume of the cube: _____

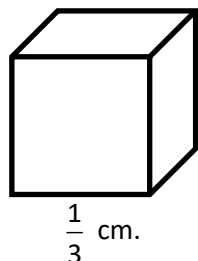

- 5) Find the area of the shaded section of the square: _____

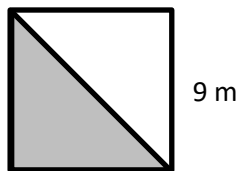

- 6) Find the area of the triangle: _____

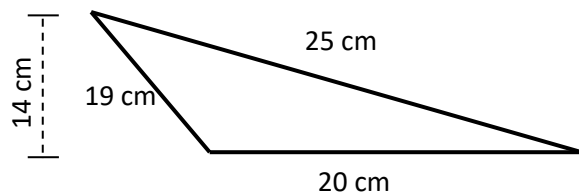

- 7) Determine the area of the trapezoid: _____

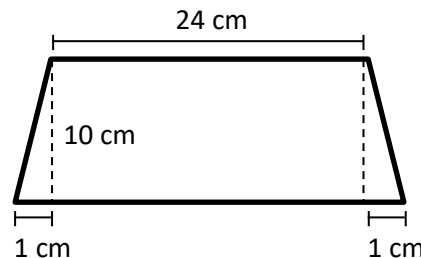

- 8) The surface area of a cube can be found by using the formula $SA = 6s^2$. Determine the surface area of a cube with a length of 8cm.

- 9) Find the area of the figure shown below: _____

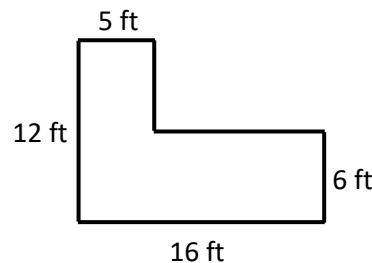

Application

- 10) If carpet costs \$4 per square yard, how much would it cost to carpet a rectangular room that is 6 yards wide and 10 yards long? _____

- 11) What is the area of the trapezoid? _____

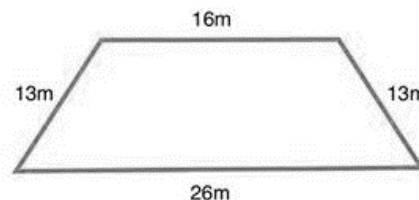

- 12) A rectangular prism is filled with small cubes of the same size. The bottom layer consists of 9 cubes, each with a volume of 2 cubic inches. If there are 3 layers of cubes in the prism, what is the volume of the rectangular prism? _____

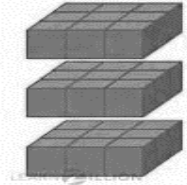

- 13) A box is made of cardboard with no overlap. The net of the box is shown below. How many square inches of cardboard is needed to make the box? _____

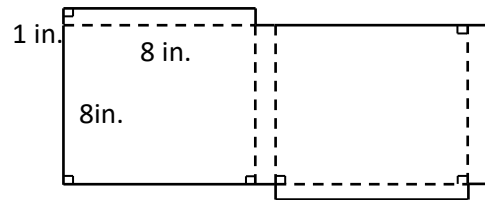

- 14) The triangular sides of the tent are equilateral, with a base of 20 inches and a height of 15 inches. The three rectangular sides of the tent are each 50 inches long and 20 inches wide. What is the surface area of the tent? _____



- 15) Mariah and Max are making a plaque to dedicate to the swaggerific saxophone players of the ECMS sixth-grade band. The center is a 10-inch square, and the edges of the frame measure 12 inches long and 12 inches wide. What is the area of the frame? _____

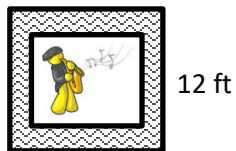

- 16) A fish tank is shown below. What is the volume of the water in the tank? _____

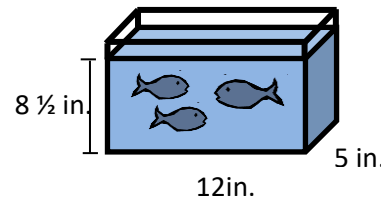

- 17) How many cubic feet are in a cubic yard? _____

- 18) The volume of a rectangular prism can be found by using the formula $V=Bh$. If the base of a prism is square with a side length of 3 inches and the height of the prism is $2\frac{1}{4}$ inches, find the volume of the prism. _____

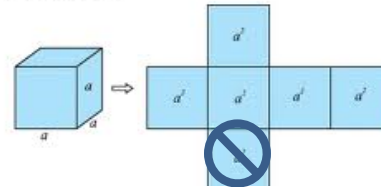

- 19) Andres is painting five faces of a storage cube (he isn't painting the bottom face). If each faces is 8 inches, how many square inches will he need to paint? _____

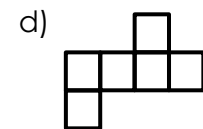
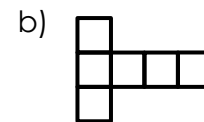
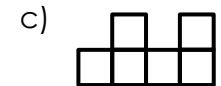
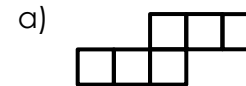

- 20) Which of the following nets could NOT be folded to form a cube?

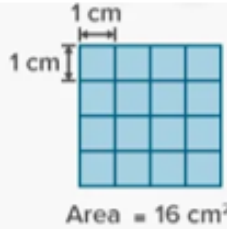

Area of Squares, Rectangles, Parallelograms, Triangles, and Trapezoids

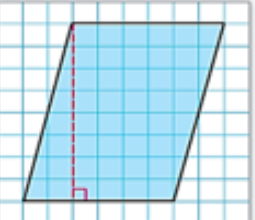
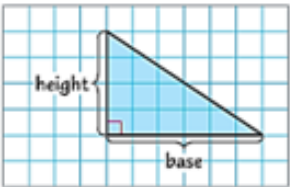
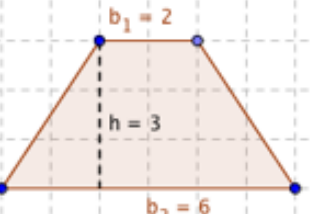
<u>Shape</u>	<u>Formula</u>	<u>Example</u>	<u>WHY/HOW</u> does this work?
Square		 $A = s^2$ $A = 4^2$ $A = 16$	
Rectangle		 $A = l \times w$ $A = 5(2)$ $A = 10$	
Parallelogram		 <p>The base is 6 units, and the height is 8 units.</p> $A = bh$ $A = 6 \cdot 8$ $A = 48$	
Triangle		 $A = \frac{1}{2}bh$ $A = \frac{1}{2}(6)(4)$ $A = \frac{1}{2}(24)$ $A = 12$	
Trapezoid		 $A = h\left(\frac{b_1 + b_2}{2}\right)$ $A = 3\left(\frac{2+6}{2}\right)$ $A = 3(4)$ $A = 12$	

Practice with Area

Name of Polygon	Rectangle	Parallelogram	Triangle	Trapezoid
Picture				
Write the formula	$A = lw$	$A = bh$	$A = \frac{1}{2}bh$	$A = h\left(\frac{b_1+b_2}{2}\right)$
Substitute for the variables (Show work)	$22(8)$	$12(9)$	$\frac{1}{2}(12)(4)$	$4\left(\frac{6+8}{2}\right)$ $4\left(\frac{14}{2}\right)$ $4(7)$
Solve. Include square units in your answer.	176 cm^2	108 in^2	24 units^2	28 units^2

Skills Practice

Find the area of each polygon. Show all steps!

Step 1: Write your formula.
Step 2: Substitute for the base(s) and height.
Step 3: Solve. Include units in your answer!

1.

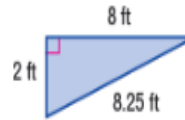

2.

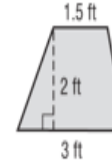

3.

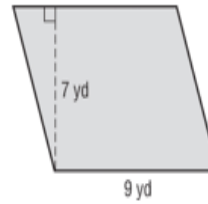

4.



5.

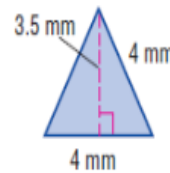

6.

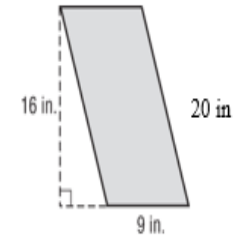

7.

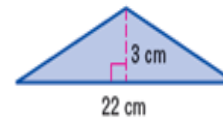

8.

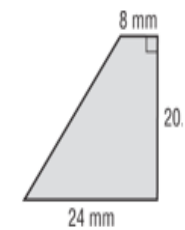

Area Error Analysis



Fill in the Flow Map with the 3 steps to solving problems on area:



Silly Sally has struck again! Analyze her work in Column #1, and circle her mistake. In Column #2, explain what she did wrong. In Column #3, work out the problems correctly, showing ALL work!

Silly Sally's Work (Circle her mistake):	What did Silly Sally do wrong?	Show Silly Sally how it's done! (Show ALL steps!)

Area of Composite Figures

A **composite figure** is a figure made of two or more two-dimensional figures. The composite figure shown to the right is made of two rectangles.

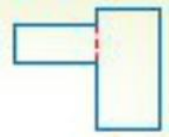

The figure below is a composite figure. How would you find its area?

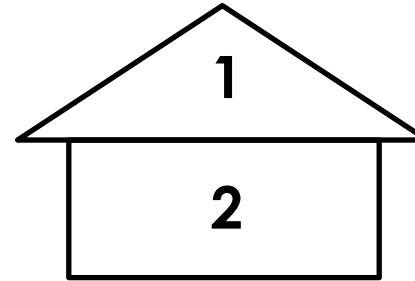

The house is made up of two shapes that you are familiar with – a triangle and a rectangle. You can “decompose” or “take apart” the figure to find the area of each piece and then find the sum of those areas to get the total area.

Try This:

Find the area of the rocket figure below.

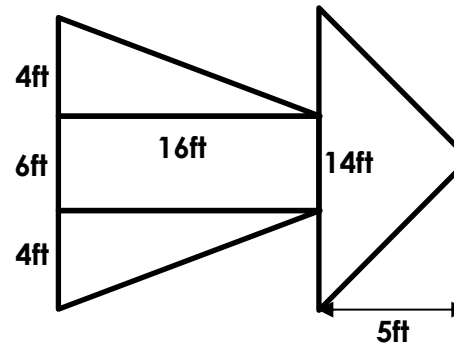

1) Find the area of each polygon that makes up the shape. Write the areas inside each polygon.

2) What is the TOTAL area of the shape? _____

Area of Composite Figures Practice

Find the area of each composite figure. Remember to show all work! (Hint: Often, you will have to draw in lines to decompose the figure. Pay careful attention to the side lengths that are given so you can figure out the side lengths that are missing!)

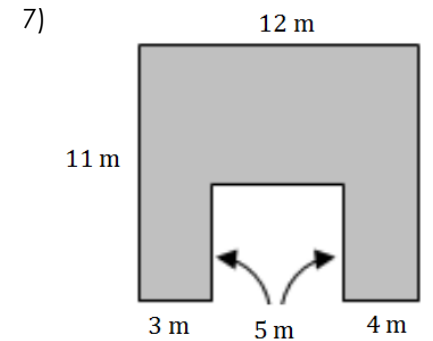
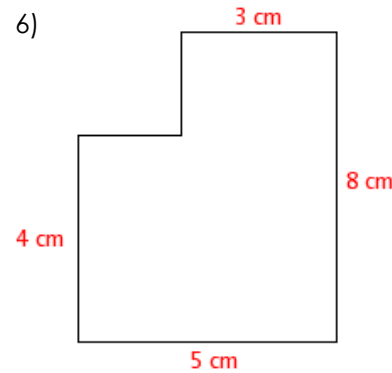
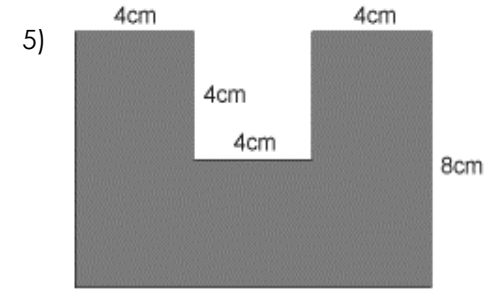
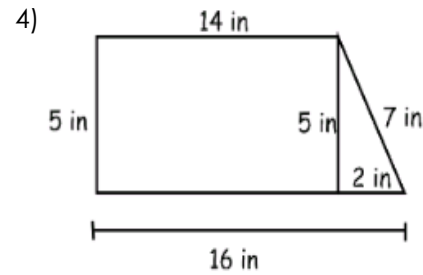
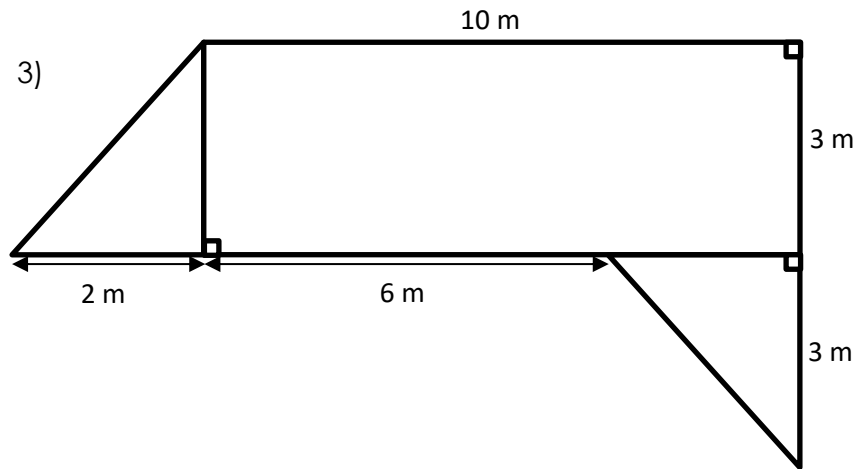
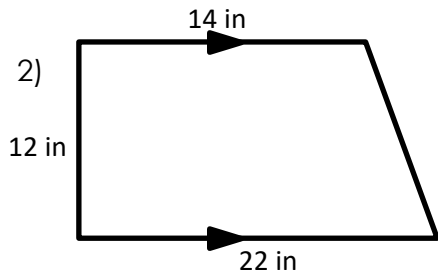
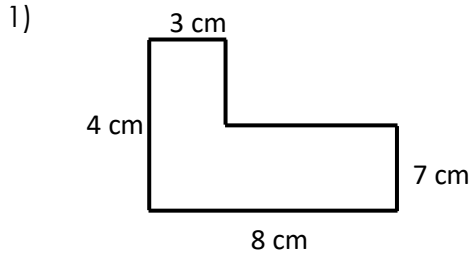

8) Match each math sentence with the correct division of the complex figure below.

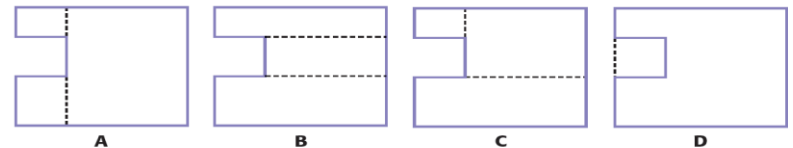
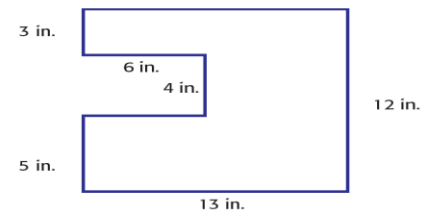

4. $(6 \times 3) + (7 \times 7) + (13 \times 5)$

5. $(6 \times 3) + (6 \times 5) + (7 \times 12)$

6. $(13 \times 12) - (6 \times 4)$

7. $(13 \times 3) + (7 \times 4) + (13 \times 5)$

Nets

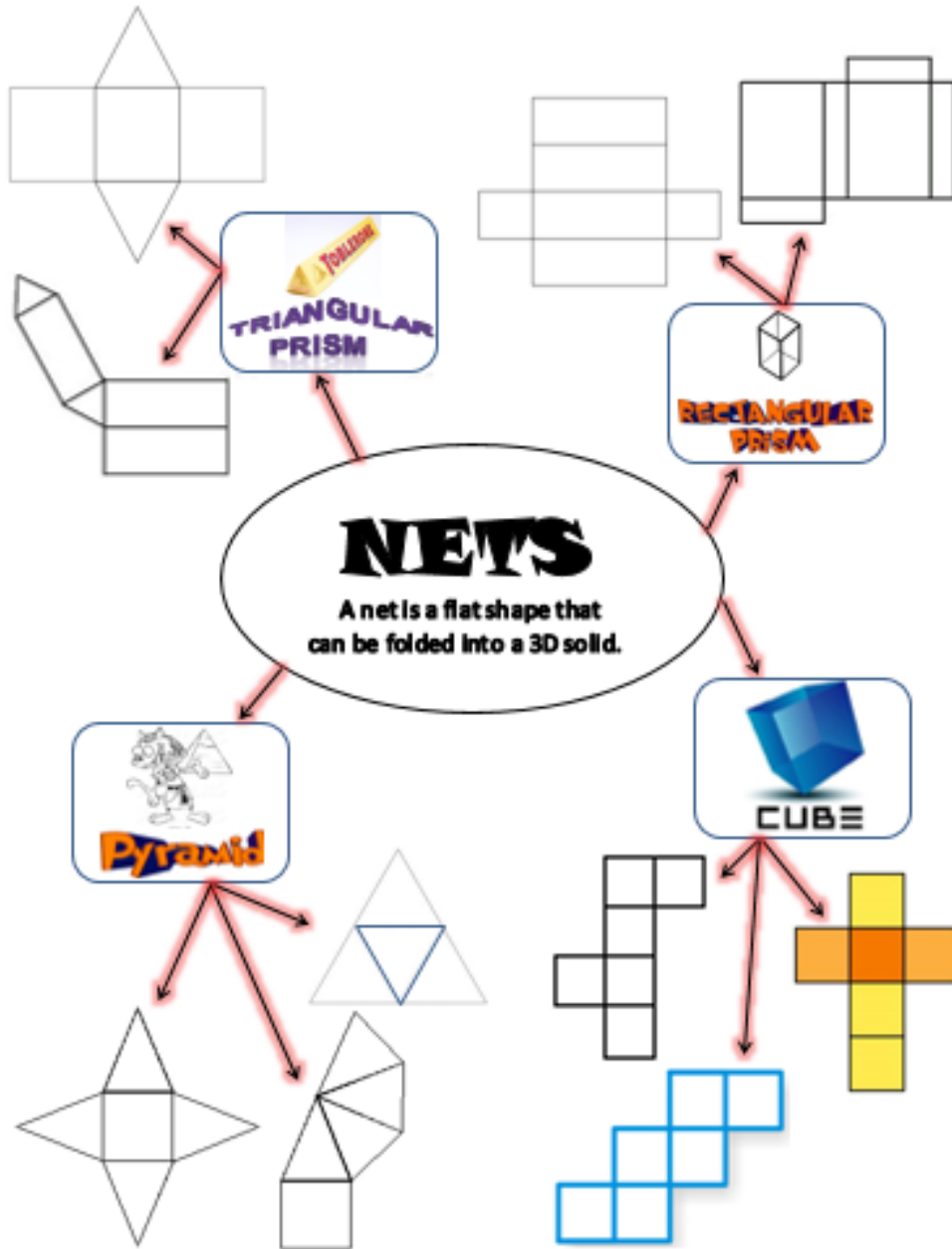







Nets of 3-Dimensional Figures

Face is a flat _____ of a solid figure.

Edge is a _____ segment where two faces of a _____ meet.

Vertex is a _____ where _____ or more edges of a solid figure meet or the pointed end of a cone opposite of its base.

FIGURE	FACES Look Like	BASE	How many faces?	NET
Cube 				
Rectangular Prism 				
Triangular Prism 				
Square Pyramid 				
Triangular Pyramid 				
Cylinder 				
Cone 				

Surface Area Notes

So... what exactly IS surface area, anyway?

To calculate the surface area of a 3D figure...

Examples of surface area:

Surface Area Practice

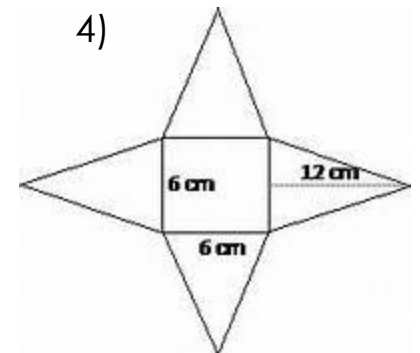
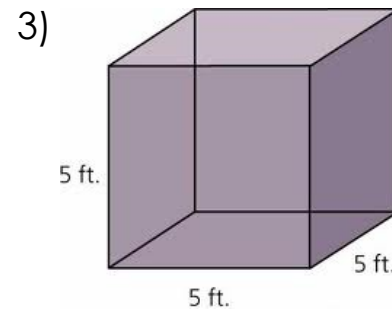
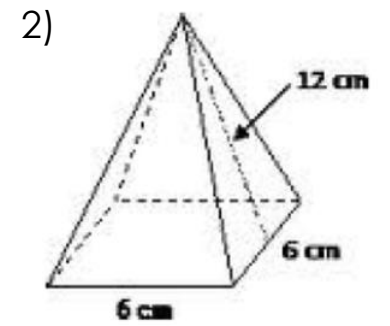
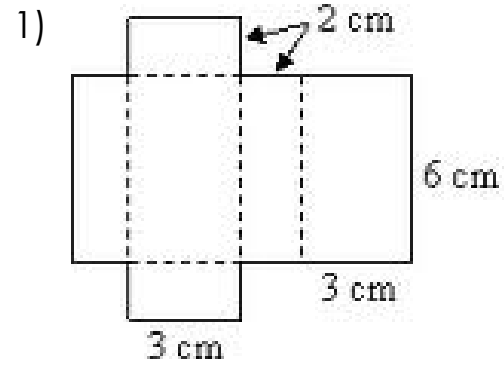

CUBE

Draw a cube **and** its net. Label its dimensions 4 inches. Then, determine the surface area.

RECTANGULAR PRISM

Draw a rectangular prism **and** its net. Label its dimensions 4 inches, 2 inches, and 5 inches. Then, determine the surface area.

SQUARE PYRAMID

Draw a square pyramid **and** its net. Label the dimensions of the base as 4 inches, and the height of the triangular faces 3 inches. Then, determine the surface area.

TRIANGULAR PYRAMID

Draw a triangular pyramid **and** its net. Label the dimensions of the base as 4 inches, and the height of the triangular faces 3 inches. Then, determine the surface area.

Surface Area Practice

1)

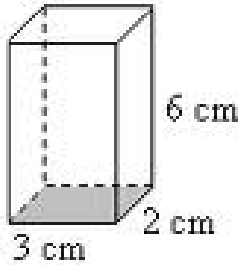

2)

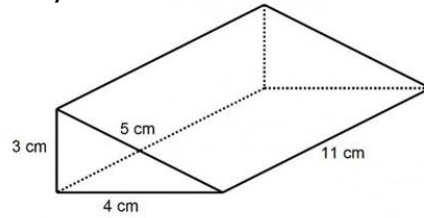

7)

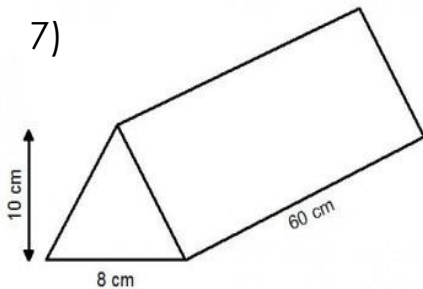

8) Find the Surface Area of a cube with side length 4cm.

Surface Area in the Real World

Solve each of the problems by drawing a net and finding the surface area.

1) A pizza box is 15 inches wide, 14 inches long, and 2 inches tall. How many square inches of cardboard were used to create the box?



2) Angelo is making a replica of an Egyptian pyramid. He is making a square pyramid with a base that is 3 feet long and 3 feet wide. The triangular sides of the pyramid each have a height of 14 feet. How much material will Angelo need to cover the pyramid?



3) Sydney is painting a rectangular toy box for her little brother. She will paint all 4 sides and the top (she will NOT paint the bottom). If the toy box is 20 inches tall, 12 inches wide, and 25 inches long, how many square inches will she need to paint?

4) DeAndre is making a tent for his hamster. It is 20 cm long, and the triangular bases are 15 cm high and 10 cm wide (see picture below). How much material will he need to make the tent?

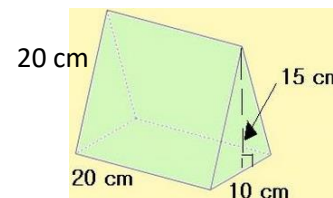

Volume of Rectangular Prisms

Volume is the amount of space *inside* a 3D object, measured in *cubic units*.

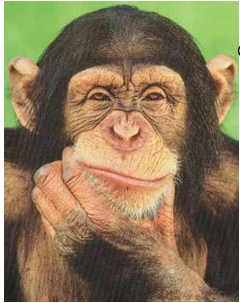

Ever wonder WHY volume is measured in *cubic units*??

Since volume measures the amount of space **INSIDE** a figure, it's like you're *packing the figure with little tiny cubes*!!

Here's a visual of a **rectangular prism** being packed with unit cubes...

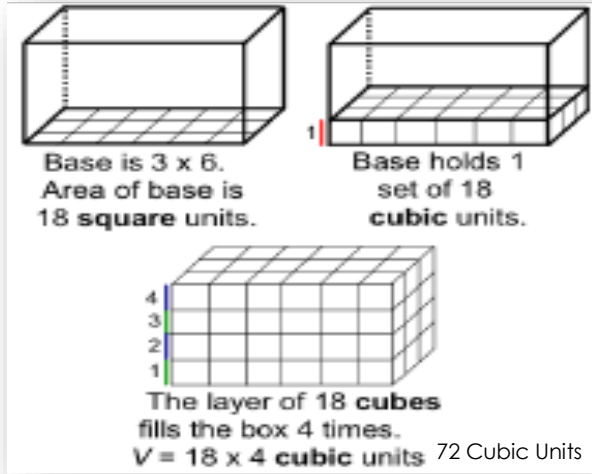

Here's a visual of a **cube** being packed with unit cubes...

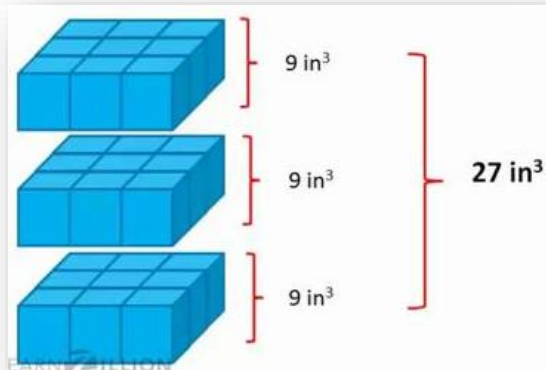

Volume is the _____ of _____ units needed to fill the space in a three dimensional (3D) figure.

Volume is always measured in cubic units.

We calculate volume you must find the area of the _____ then multiply it by the _____.

This can be written as _____ • _____.

OR _____ • _____ • _____ for a rectangular prism.

Example:

Find the volume of the rectangular prism below.

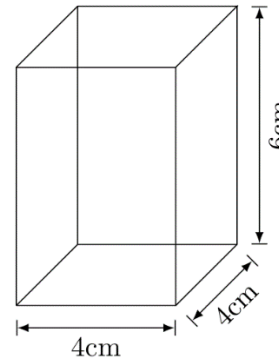

$$V = B \cdot h$$

$$V = l \cdot w \cdot h$$

$$V = 4 \cdot 4 \cdot 6$$

$$V = 96 \text{ cm}^3$$

You Try:

Find the volume.

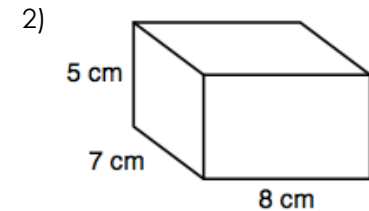
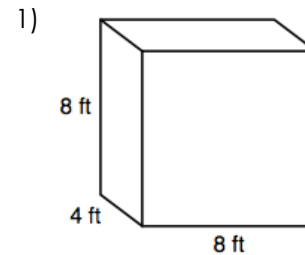

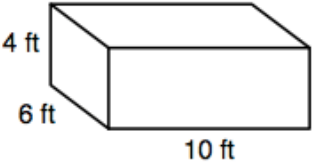
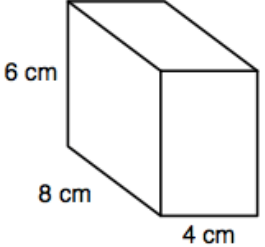
<p>3) </p>	<p>4) </p>
<p>5) Find the volume of a rectangular prism with $B = 78\text{ft}^2$ and $h = 23\text{ ft}$.</p>	<p>6) Find the volume of a rectangular prism with $l = 4.2\text{cm}$, $w = 3.8\text{cm}$, and $h = 6\text{cm}$.</p>
<p>7) Find the volume of a rectangular prism with $l = 8\frac{1}{4}\text{ in.}$, $w = 9\text{in}$ and $h = 15\text{in.}$</p>	<p>8) Find the missing dimension of the rectangular prism. $L = 14\text{ cm}$ $W = ?$ $H = 3\text{ cm}$ $V = 294\text{ cm}$</p>

Volume of Rectangular Prisms with Fractional Edges

Let's calculate the volume of a rectangular prism with a length of 6 units, a width of 3 units, and a height of $3\frac{1}{2}$ units.

Look at the picture! →

The bottom layer contains 6 units across and 3 units back, for a total of 18 units.

Then, there are $3\frac{1}{2}$ layers of 18 units. (You have 3 layers, and then half of another layer.)

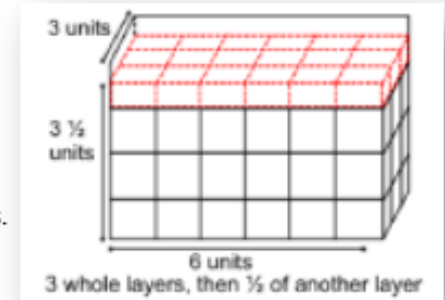

So, the total volume of this figure is $18 + 18 + 18 + 9 = 63$ cubic units.

Let's calculate the amount of water that Nora can pour into her fish tank that is 10 inches long, 6 inches wide, and $5\frac{1}{4}$ inches deep.

The bottom of the tank is 10 inches long and 6 inches wide, so the bottom layer is 60 cubic inches.

Then, there are $5\frac{1}{4}$ layers of 60 units. The volume of the tank is...

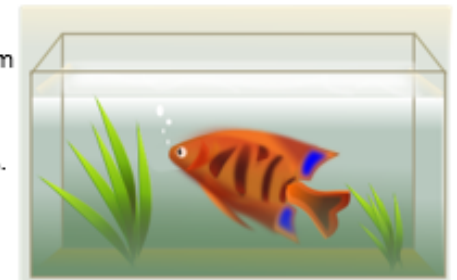

$$\begin{array}{l}
 \underbrace{5 \text{ layers of } 60}_{60 + 60 + 60 + 60 + 60} + \frac{1}{4} \text{ layer} \\
 \downarrow \\
 60 + 60 + 60 + 60 + 60 + 15 = 315 \text{ cubic inches}
 \end{array}$$



You Try:

Find the volume of a rectangular prism with a length of 3cm, a width of $2\frac{1}{2}$ cm, and a height of 4 cm.

Volume Error Analysis

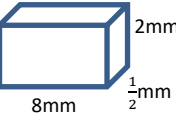

Sally is a silly little girl that makes silly mistakes! Analyze her work in Column #1, and circle her mistake. In Column #2, explain what she did wrong. In Column #3, show how Silly Sally should work out the problem. Show ALL work!

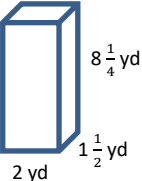
Silly Sally's Work (Circle her mistake):	What did Silly Sally do wrong?	Show Silly Sally how it's done! (Show ALL steps!)
 $V = lwh$ $V = 4 \cdot 4 \cdot 4$ $V = 12 \text{ m}^3$	<p>She multiplied 4(3) instead of multiplying 4(4)(4).</p>	<p>64 cubic meters</p>
 $V = lwh$ $V = 8 \cdot \frac{1}{2} \cdot 2$ $V = 4 \cdot 2$ $V = 8 \text{ mm}^2$	<p>She wrote the final answer in square units instead of cubic units.</p>	<p>8 cubic mm</p>
 $V = lwh$ $V = \frac{2}{3} \cdot \frac{2}{3} \cdot \frac{2}{3}$ $V = \frac{6}{9} = \frac{2}{3} \text{ in}^3$ Cube = $\frac{2}{3}$ in. tall	<p>She added the numerators and denominators, but she should have multiplied.</p>	<p>$\frac{8}{27}$ cubic inches</p>
 $V = lwh$ $V = 8 \frac{1}{4} \cdot 2 \frac{1}{2} \cdot 3$ $V = 16 \frac{1}{8} \cdot 3$ $V = 48 \frac{1}{8} \text{ yd}^3$	<p>When she multiplied $8 \frac{1}{4}$ by $2 \frac{1}{2}$, she multiplied the whole numbers and fractions separately. She should have converted to improper fractions before multiplying.</p>	<p>$61 \frac{7}{8}$ cubic yds</p>
 $V = lwh$ $V = 4 \frac{1}{2} \cdot 1 \frac{1}{2} \cdot 2$ $V = \frac{8}{2} \cdot \frac{3}{2} \cdot 2$ $V = \frac{24}{4} \cdot 2$ $V = 12 \text{ yd}^3$	<p>She wrote the wrong height. She also converted $4 \frac{1}{2}$ incorrectly to $\frac{8}{2}$.</p>	<p>$24 \frac{3}{4}$ cubic yds</p>

More Volume Practice

Determine the Volume of each rectangular prism or cube below. Include units and show your work!

- A cube that is $12 \frac{1}{8}$ yards wide **1,782 $\frac{289}{512}$ cubic yds**
- The box with dimensions of $6 \text{ ft} \cdot 4 \text{ ft} \cdot 1 \frac{1}{2} \text{ ft}$ **36 cubic ft**
- Determine the Volume of a rectangular truck bed that is 12 feet long, $5 \frac{1}{4}$ feet wide, and $3 \frac{1}{5}$ feet deep. **$201 \frac{3}{5}$ cubic ft**
- How much water can be poured into a cubic tank that is $2 \frac{1}{2}$ feet long? **$15 \frac{5}{8}$ cubic ft**
- What is the volume of a gift box that is $3 \frac{1}{2}$ inches wide, 2 inches tall, and 6 inches long? **42 cubic inches**

SURFACE AREA AND VOLUME PRACTICE

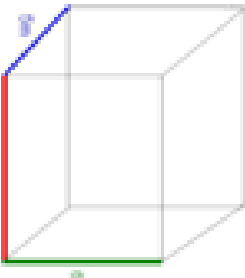
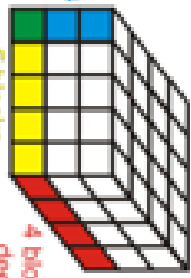
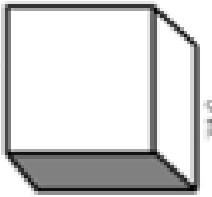
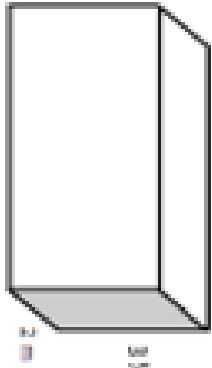
Rectangular Prism:	Surface Area (Show work and circle your answer.) (It may help to draw a net!)	Volume (Show work and circle your answer.) $V = lwh$ OR $V = Bh$
	1) SA = _____	2) V = _____
	3) SA = _____	4) V = _____
	5) SA = _____	6) V = _____
	7) SA = _____	8) V = _____

9) Circle the choices that relate to **volume**. Underline the choices that relate to **surface area**.

Filling a pool with water

Wrapping a present

The amount of cereal in a box

Painting a doghouse

10) How are surface area and volume alike? _____

11) Name 2 ways surface area and volume are different.

a. _____

b. _____